

The RADYBAN tool: Reliability Analysis with DYnamic BAYesian Networks

Faculty: *Andrea Bobbio, Stefania Montani, Luigi Portinale*

Post-doc: *Daniele Codetta-Raiteri*

Students: *Stefano Di Nolfo, Marco Varesio*

Outline

- Classes of models in the Dependability/Reliability field
- Dynamic Bayesian Networks (DBN)
 - Definition
 - Case studies
- RADYBAN tool
 - Architecture and use
 - Conversion rules from Dynamic Fault Tree (DFT) to DBN
 - Case study

Reliability evaluation

- **Measurement-based** evaluation
 - It requires the observation of the behaviour of the system physical components.
 - It may be expensive or unpractical.
- **Model-based** evaluation
 - A model is a convenient abstraction of the system.
 - A model has a certain degree of accuracy.
 - A model can be the object of analysis or simulation.
 - **Models classification:**
 - Combinatorial models
 - State space based models
 - Models with conditional local dependencies

Combinational models

- They represent the structure of the system in terms of logical connection of working (failed) components in order to obtain the system success (failure).
 - **Fault Trees**, Reliability Block Diagrams, Reliability Graphs
 - Easy to use, concise, analytically tractable
 - Limited modeling power

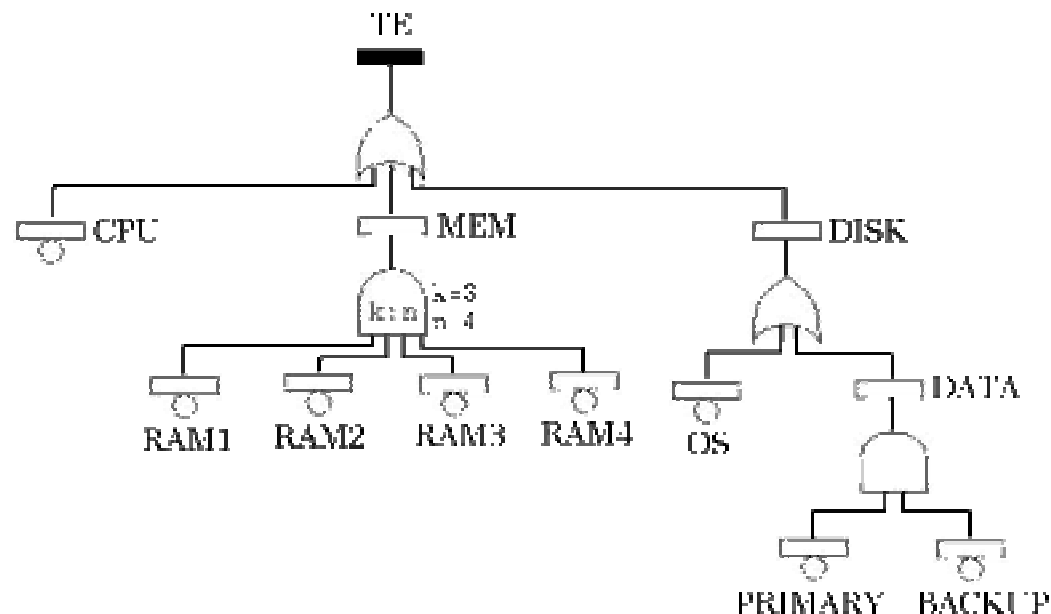

State space based models

- They enumerate the set of meaningful states and state transitions of the system
 - **Markov Chains**, Markov Decision Processes, Petri Nets
 - State space may be over-specified with respect to the modeling needs
 - Dynamic behavior of the system may lead to the explosion of the state space size

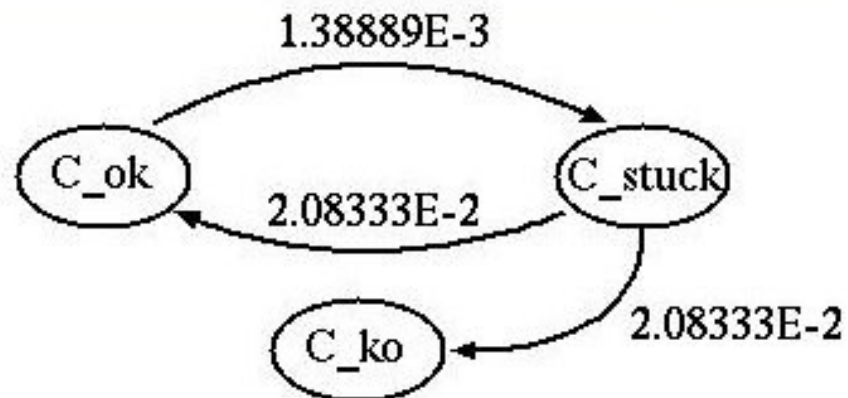

Models with conditional local dependencies

- Bayesian (or Belief) Networks (BN) are a widely used formalism for representing uncertain knowledge in probabilistic systems, applied to a variety of real-world problems
- BN are defined by a directed acyclic graph in which discrete random variables are assigned to each node, together with the conditional dependence on the parent nodes (Conditional Probability Table (CPT))
 - Root nodes are nodes with no parents, and marginal prior probabilities are assigned to them

Bayesian Networks

- Diagnostic inference
 - $\Pr(\text{cause} \mid \text{effect})$
 - $\Pr(\text{Sprinkler} \mid \text{Wet grass})$
 - $\Pr(\text{Cloudy} \mid \text{Wet grass})$
- Causal inference
 - $\Pr(\text{effect} \mid \text{cause})$
 - $\Pr(\text{Wet grass} \mid \text{Cloudy})$
 - $\Pr(\text{Wet grass} \mid \text{Sprinkler})$
- ...

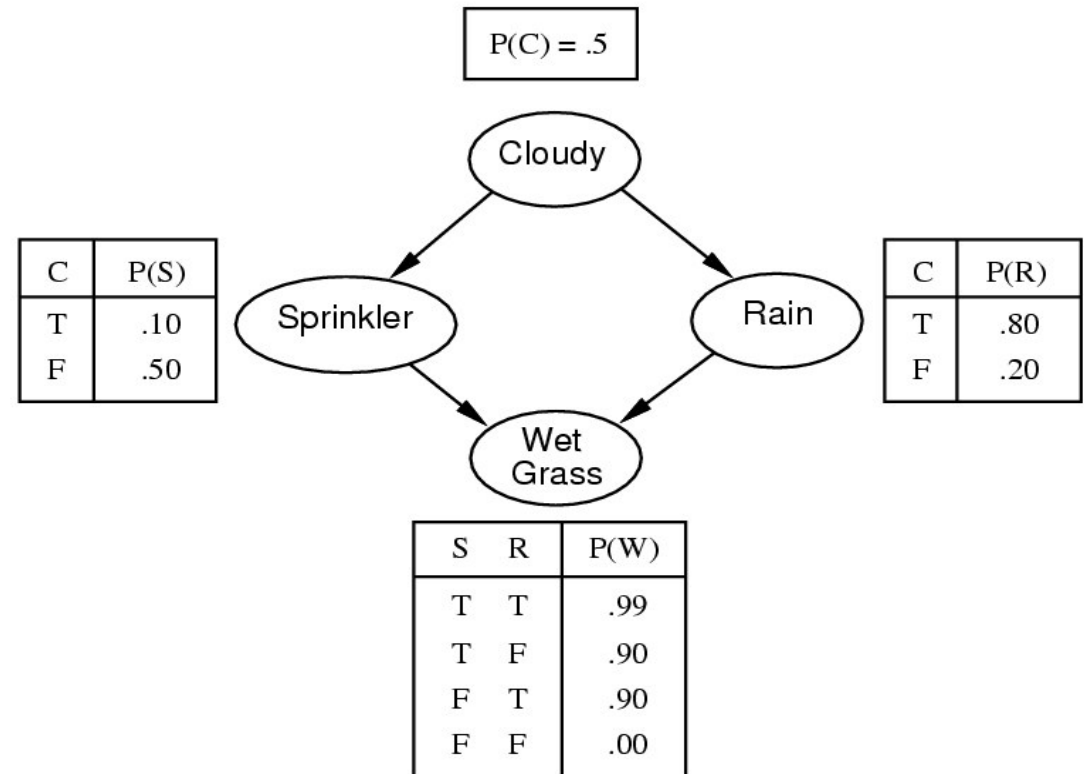

- Exact algorithms (*Clustering, Conditioning, Variable Elimination* (Factoring), ...) or approximated algorithms (*Stochastic Simulation*) for BN inference

Inference in BN

- Find $\Pr(Q=q \mid E=e)$
 - Q is the query variable
 - E is the set of evidence variables

$$\Pr(q \mid e) = \frac{\Pr(q, e)}{P(e)}$$

- X_1, \dots, X_n are network variables except Q, E .

$$\Pr(q, e) = \sum_{x_1, \dots, x_n} \Pr(q, e, x_1, \dots, x_n)$$

- Y_1, \dots, Y_n are network variables except E .

$$\Pr(e) = \sum_{y_1, \dots, y_n} \Pr(e, x_1, \dots, x_n)$$

Inference example

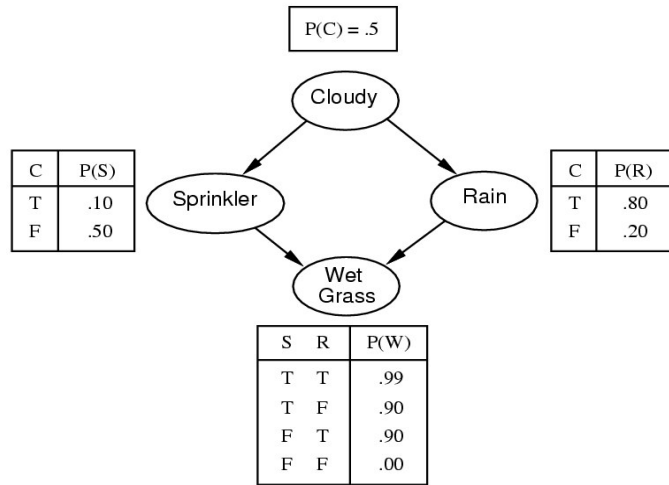

Joint probability distribution

$$P(\bar{c}, \bar{s}, \bar{r}, \bar{w}) = P(\bar{c})P(\bar{s} | \bar{c})P(\bar{r} | \bar{c})P(\bar{w} | \bar{s}, \bar{c}) = p1 \quad (0.5 \cdot 0.5 \cdot 0.8 \cdot 1 = 0.2)$$

$$P(\bar{c}, \bar{s}, \bar{r}, w) = P(\bar{c})P(\bar{s} | \bar{c})P(\bar{r} | \bar{c})P(w | \bar{s}, \bar{c}) = p2$$

$$P(\bar{c}, \bar{s}, r, \bar{w}) = P(\bar{c})P(\bar{s} | \bar{c})P(r | \bar{c})P(\bar{w} | \bar{s}, \bar{c}) = p3$$

⋮

$$P(c, s, r, w) = P(c)P(s | c)P(r | c)P(w | s, c) = p16$$

Query:

$$P(\bar{c} | \bar{r}, w) = \frac{P(\bar{c}, \bar{r}, w)}{P(\bar{r}, w)} = \frac{P(\bar{c}, \bar{s}, \bar{r}, w) + P(\bar{c}, s, \bar{r}, w)}{P(\bar{c}, \bar{s}, \bar{r}, w) + P(\bar{c}, s, \bar{r}, w) + P(c, \bar{s}, \bar{r}, w) + P(c, s, \bar{r}, w)}$$

Dynamic Bayesian Network

- DBN introduce a **discrete** temporal dimension:
 - The system is represented at several time slices
 - Conditional dependencies among variables at different slices, are introduced to capture the temporal evolution.
 - Time invariance is assumed: typically 2 time slices ($t, t+\Delta$) are assumed in DBN: Markovian assumption

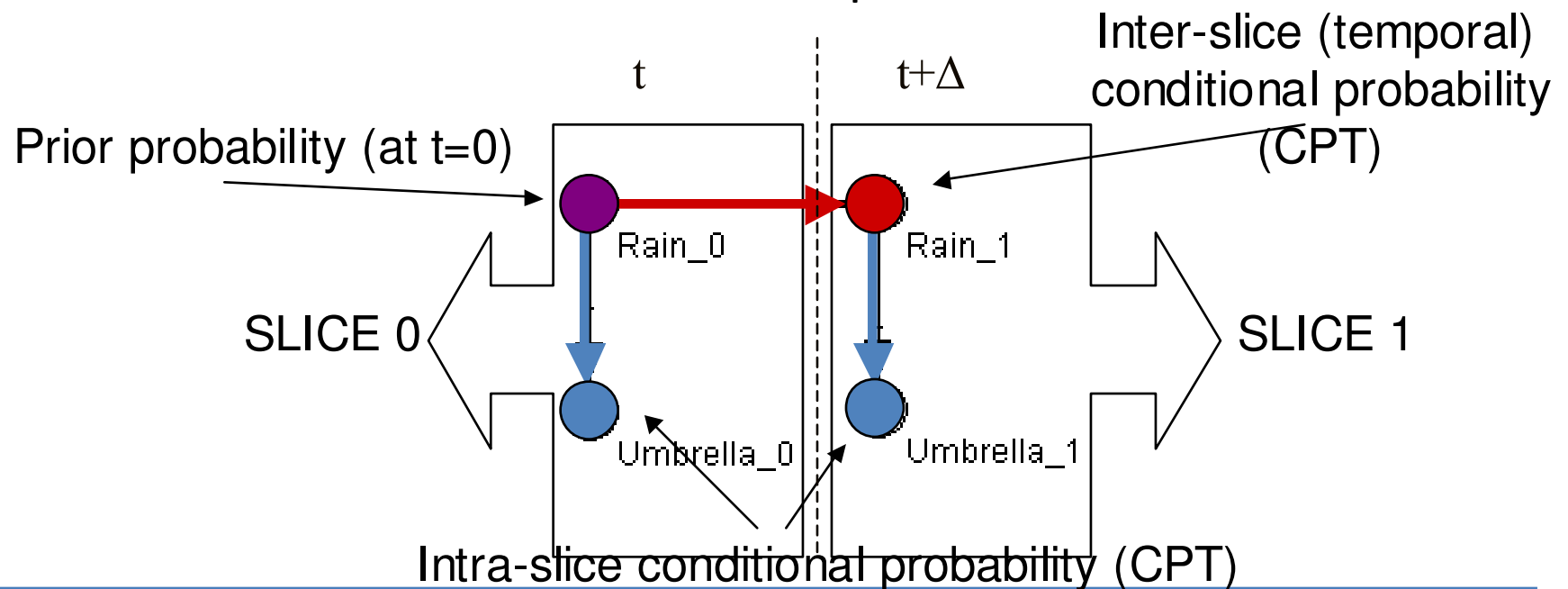

Inference on DBN

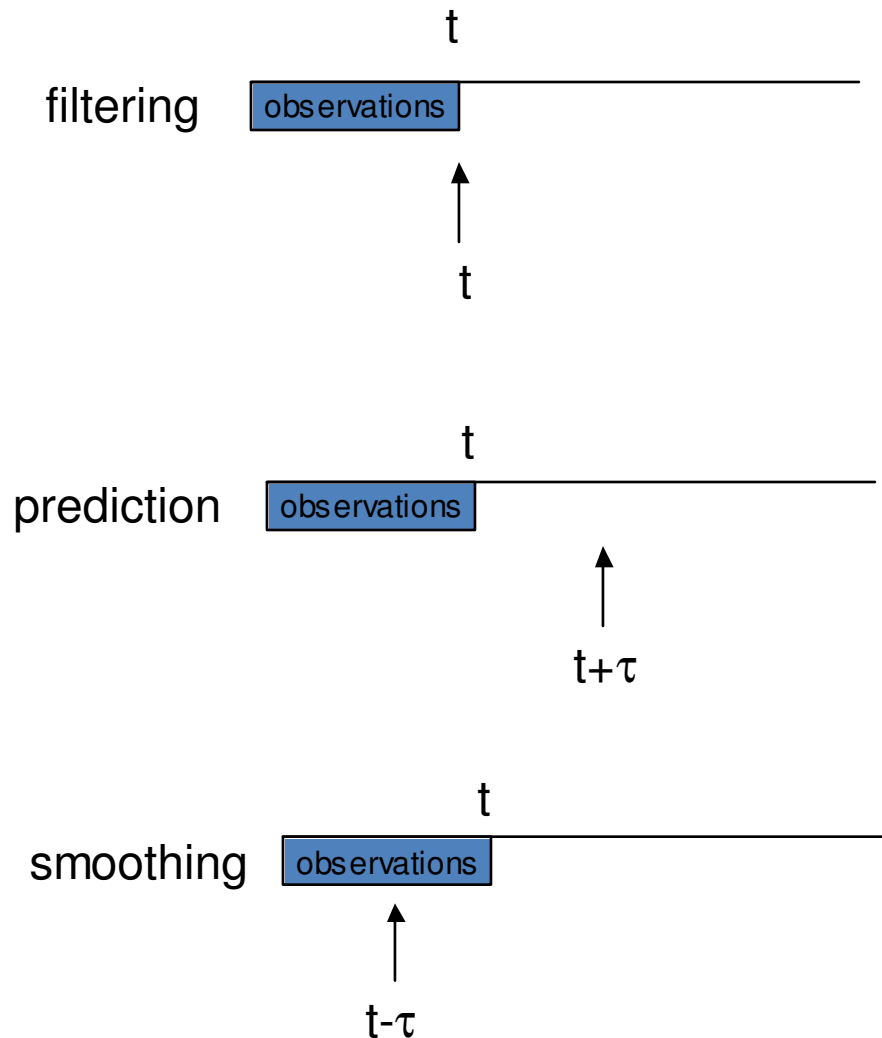

Inference algorithms:

- Slice Junction Tree (Exact)
- Boyen-Koller (Approximated)
- ...

DBN model and analysis of a benchmark

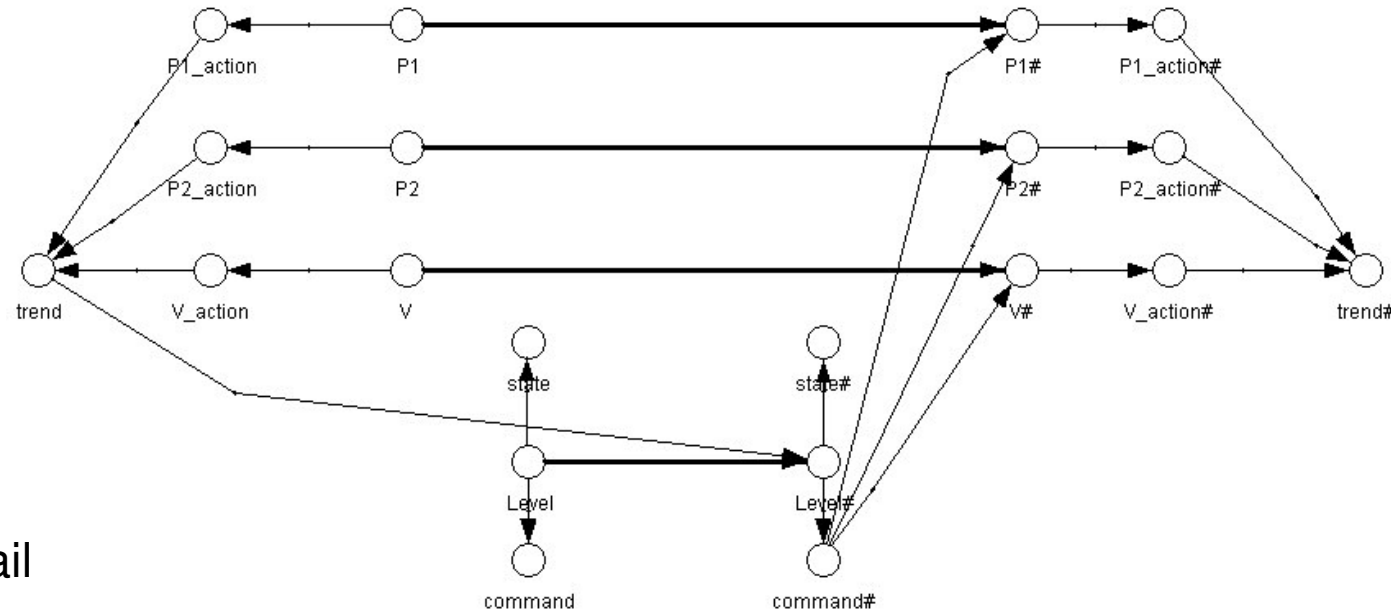
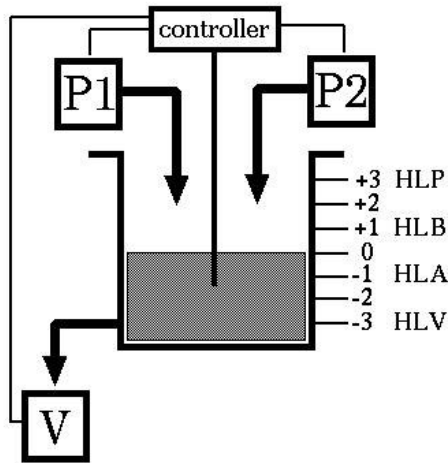

Each component may fail

Control laws:

- $H \leq HLA \Rightarrow P1:ON, P2:ON, V:OFF.$
- $H \geq HLB \Rightarrow P1:OFF, P2:OFF, V:ON.$

Failure conditions:

- Dry out ($H < HLV$)
- Overflow ($H > HLP$)

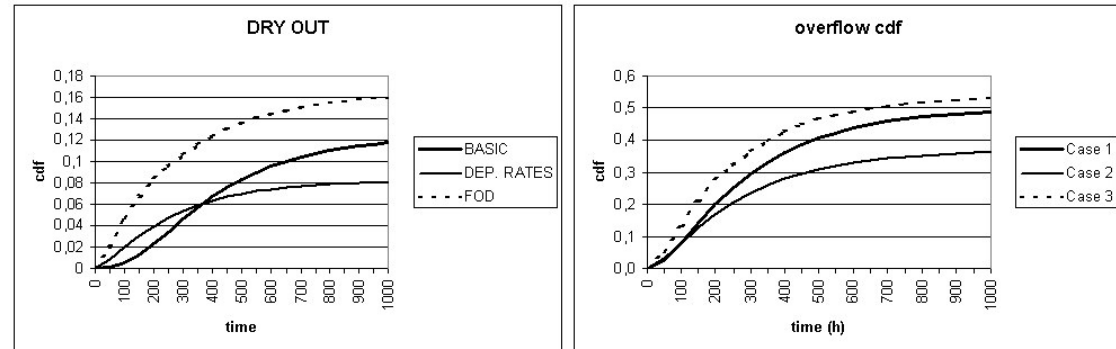

DBN model of cascading effects in a power grid

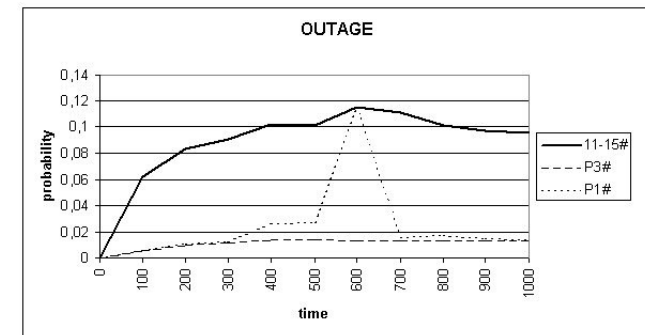
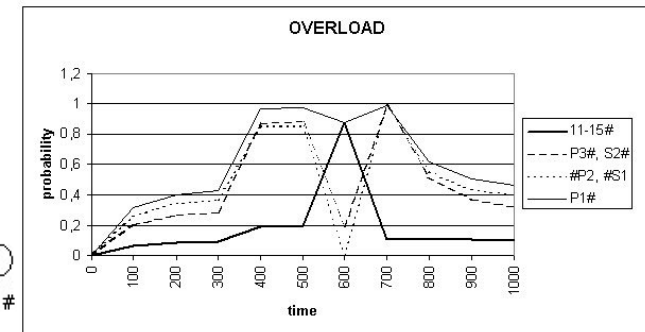
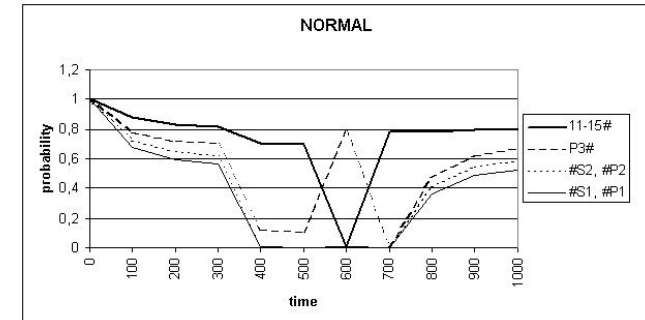
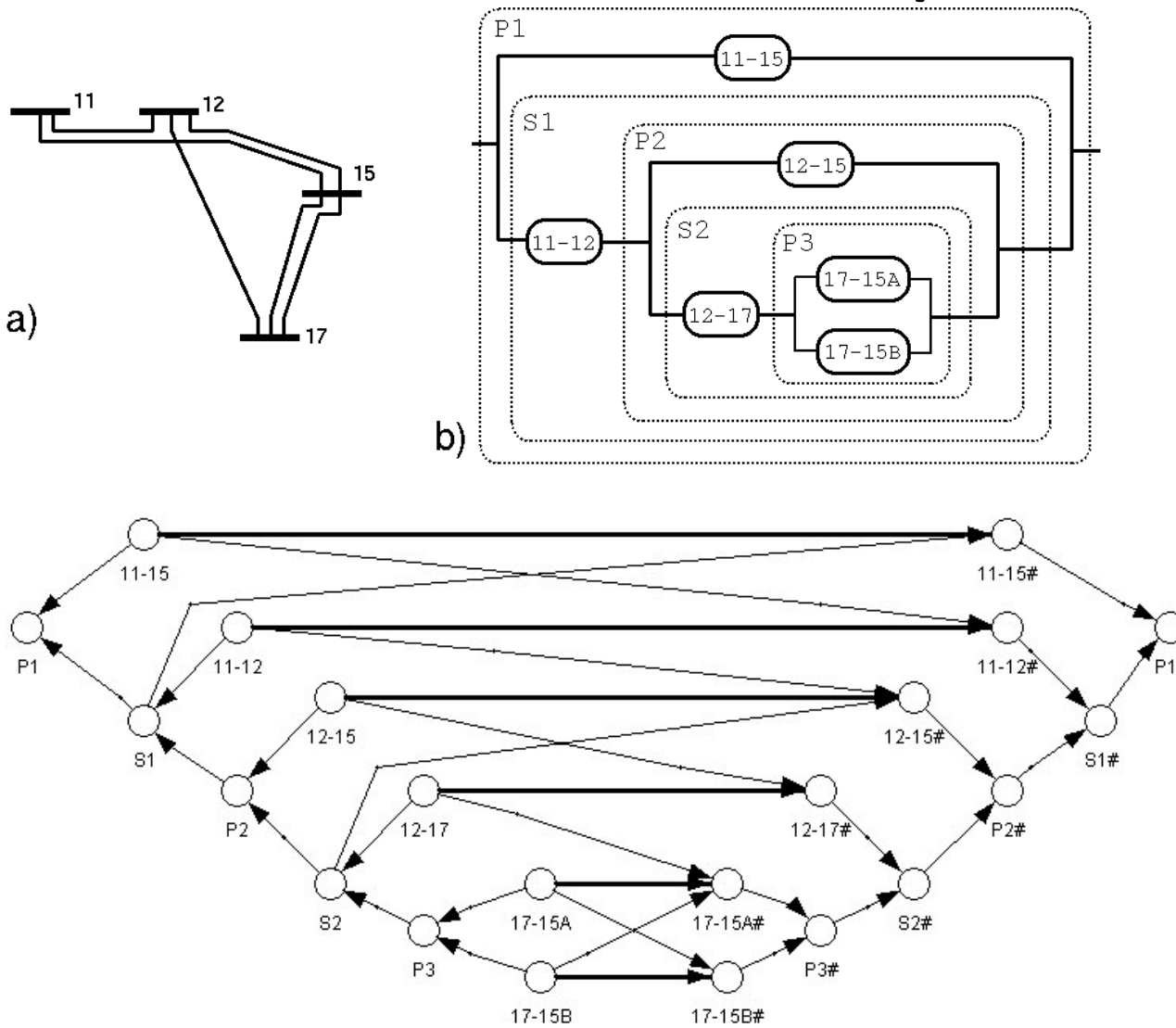

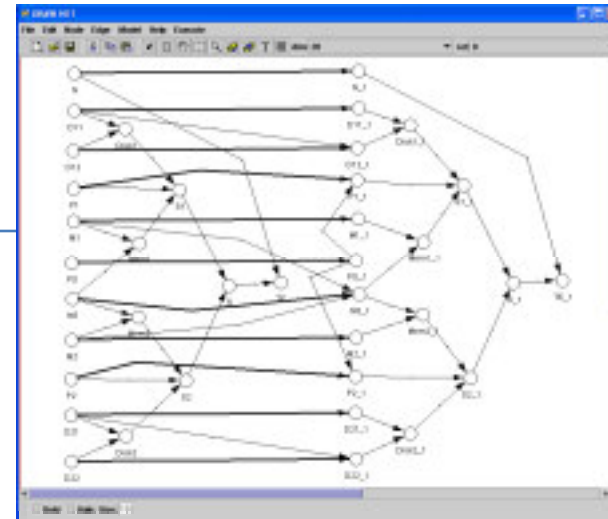

RADYBAN architecture and use (1)

DFT2DBN

DBN analyzer

DBN.xml

Results

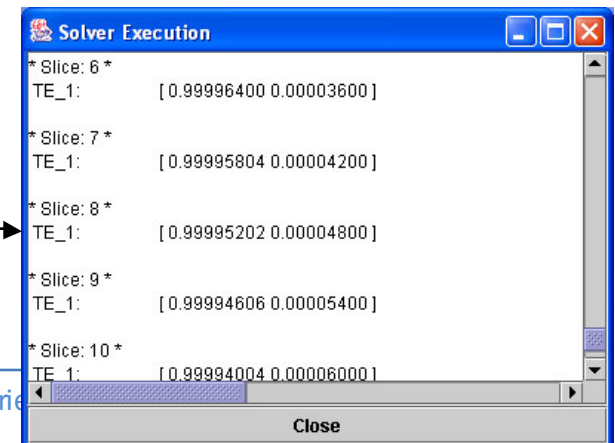

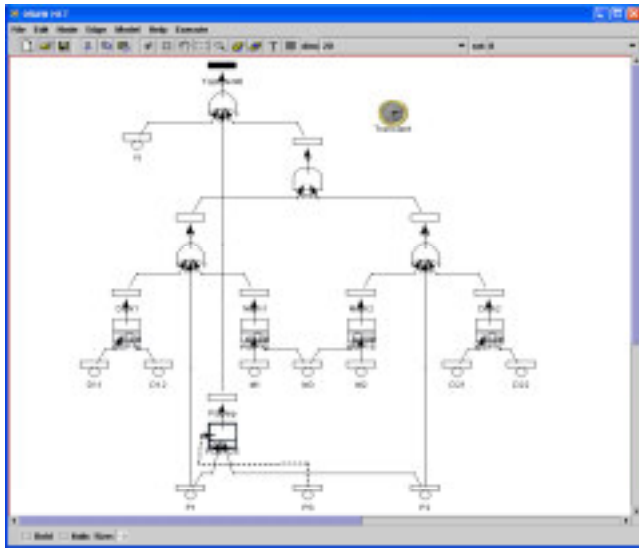

DFT.xml

DFT2DBN

DBN.xml

DBN.xml

DBN analyzer

Results

RADYBAN architecture and use (2)

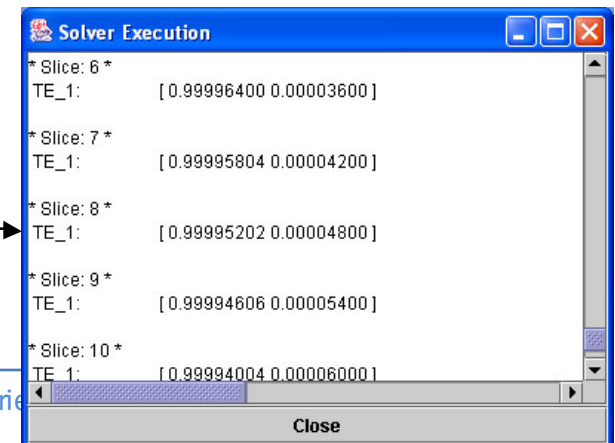

Slice	TE_1	Value 1	Value 2
* Slice: 6 *	TE_1:	[0.99996400	0.00003600]
* Slice: 7 *	TE_1:	[0.99995804	0.00004200]
* Slice: 8 *	TE_1:	[0.99995202	0.00004800]
* Slice: 9 *	TE_1:	[0.99994606	0.00005400]
* Slice: 10 *	TE_1:	[0.99994004	0.00006000]

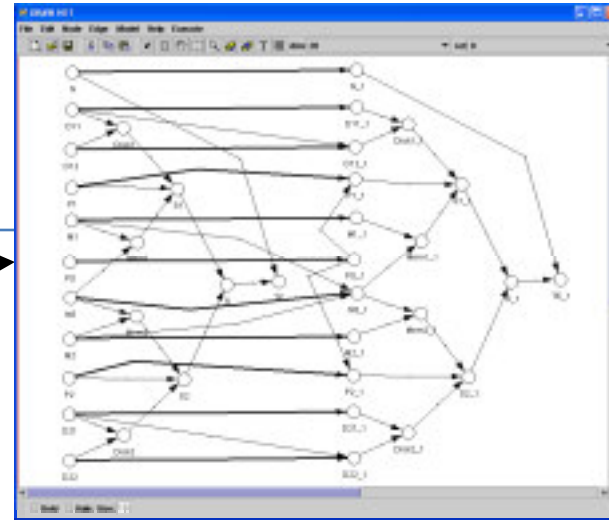
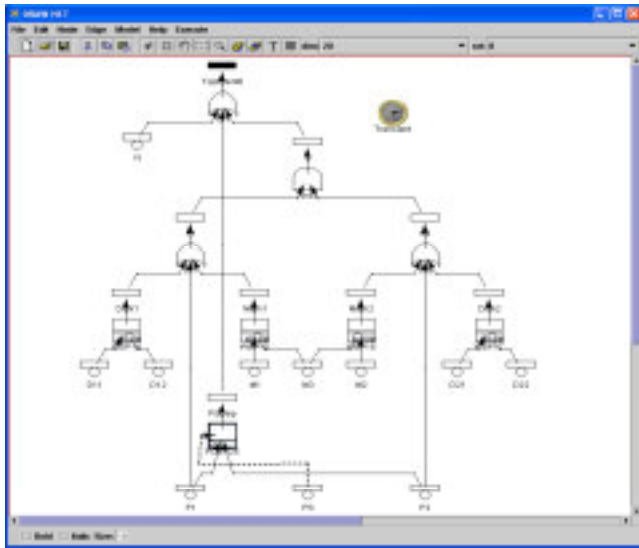

RADYBAN architecture and use (3)

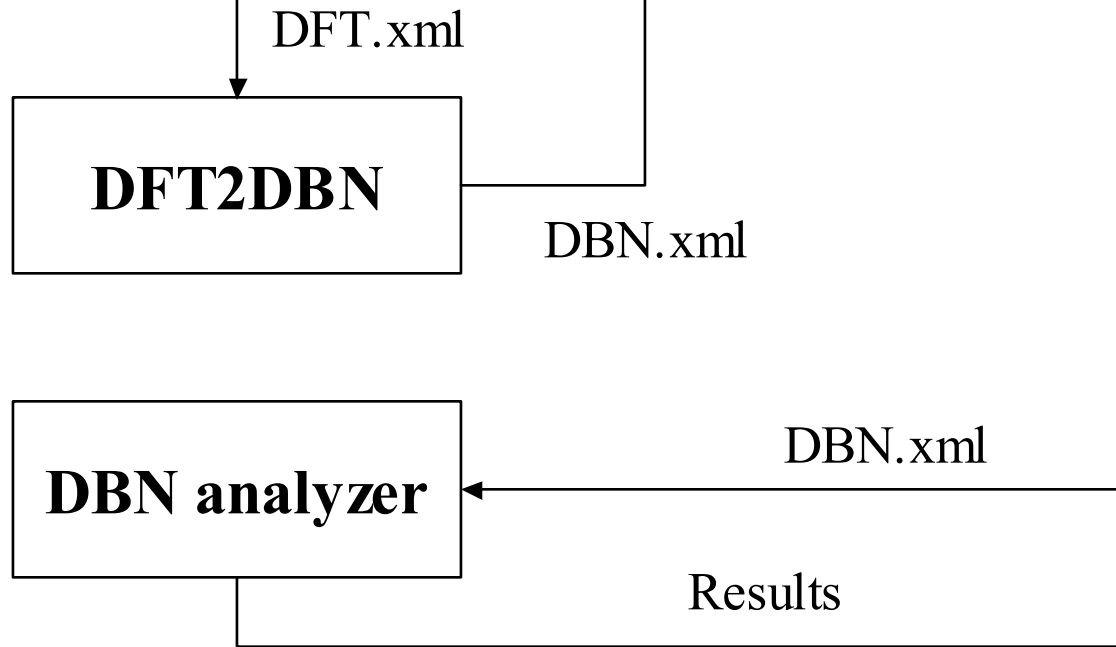
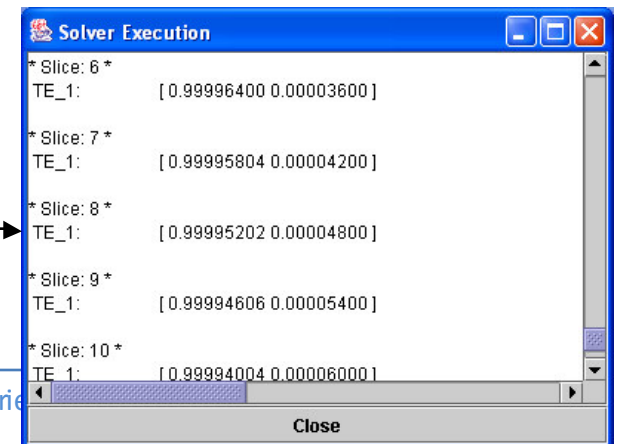
Slice	TE_1
* Slice: 6 *	[0.99996400 0.00003600]
* Slice: 7 *	[0.99995804 0.00004200]
* Slice: 8 *	[0.99995202 0.00004800]
* Slice: 9 *	[0.99994606 0.00005400]
* Slice: 10 *	[0.99994004 0.00006000]

The screenshot displays the Draw-Net software interface. On the left, a 'Property Page' window shows the configuration for a 'Transient' node, with properties like 'name', 'visibility', 'lower', 'upper', 'step', and 'discr'. Below it, the 'Solver Execution' window shows the inference results for various time slices (0, 1000, 2000, 3000, 4000, 5000) and the CPU time used (14.422 seconds). The main window, 'DRAW NET', shows a complex fault tree diagram with nodes labeled 'And4', 'Or7', 'Or8', 'WSP10', 'WSP15', 'WSP20', 'WSP23', 'D11', 'D12', 'M1', 'M3', 'M2', 'D21', 'D22', 'PS', 'R1', 'P2', and 'FDEP28'. A menu is open over the diagram, listing options for 'DBN Filtering' and 'DBN Smoothing' with radio buttons for 'JT', 'BK exact', and 'BK fully fact.'.

Draw-Net GUI

<http://www.draw-net.com>

INTEL PNL C++ libraries for DBN inference
<http://sourceforge.net/projects/openpnl/>

Fault Tree extensions

- FT modeling power is limited by several assumptions:
 - Events as binary variables (working / failed)
 - basic events independency
 - Only Boolean gates

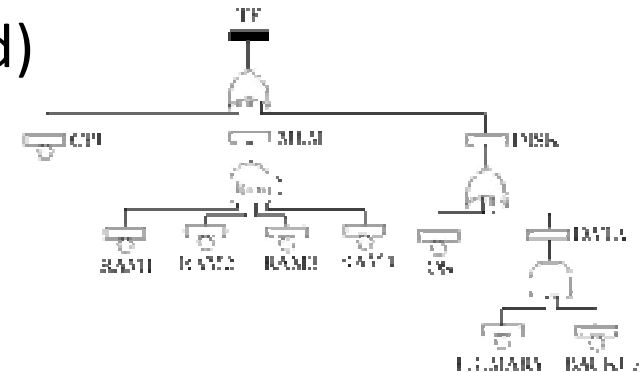

- Extensions to the FT formalism in the literature:
 - *Parametric Fault Tree* (PFT)
 - ***Dynamic Fault Tree*** (DFT)
 - *Repairable Fault Tree* (RFT)
 - *Non deterministic Repairable Fault Tree* (NdRFT)
 - ...

Dynamic Fault Trees

- A dependency arises when the failure behaviour of a component depends on the state of another item (component, subsystem, system).
- DFTs are characterized by the dynamic gates
 - Functional dependencies (FDEP gate)
 - Temporal dependencies (PAND gate, SEQ gate)
 - (Warm) spare components (WSP gate): multi-state components

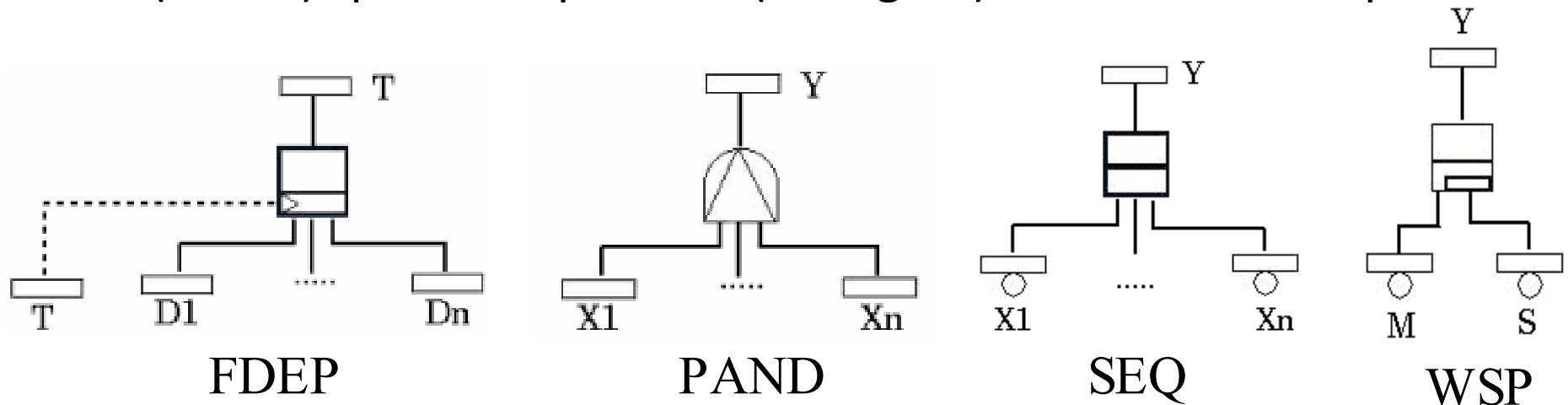

Spare components

- M is the main component; S is its spare component.
- States of S:
 - Stand-by (dormant): $\alpha_s \lambda_s$
 - Working: λ_s
 - Failed
- λ_s is the failure rate
- α_s is the dormancy factor
- Warm spare: $0 < \alpha < 1$
- Cold spare: $\alpha = 0$
- Hot spare: $\alpha = 1$

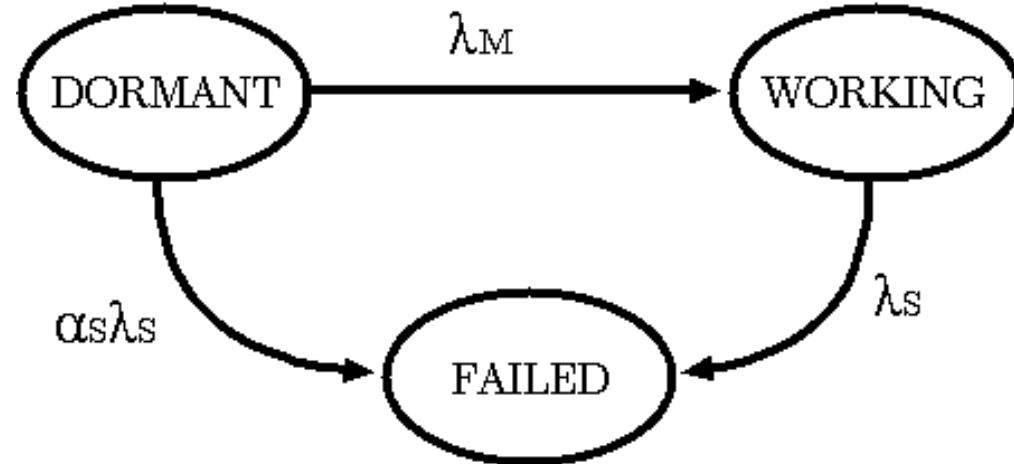

Cardiac Assist System

- The failure of either one of the modules causes the whole system failure:
 - The CPU module consists of the primary cpu P and a warm spare B:
 - Both P and B are functionally dependent on a cross switch CS and a system supervision SS
 - Both P and B are considered as repairable
 - The Motor module consists of the primary motor MA and a cold spare MB:
 - MB turns into operation when the MA fails, because of a motor switching component MS
 - if MS fails before MA, then the spare cannot become operational
 - The Pump module is composed by two primary pumps PA and PB running in parallel and a cold spare PS

DFT of the case study

Comp.	λ (1/h)	α
P	0.50E-3	0.5
B	0.50E-3	
CS	0.20E-3	
SS	0.20E-3	0
MA	1.00E-3	
MB	1.00E-3	
MS	0.01E-3	
PA	1.00E-3	
PB	1.00E-3	0
PS	1.00E-3	

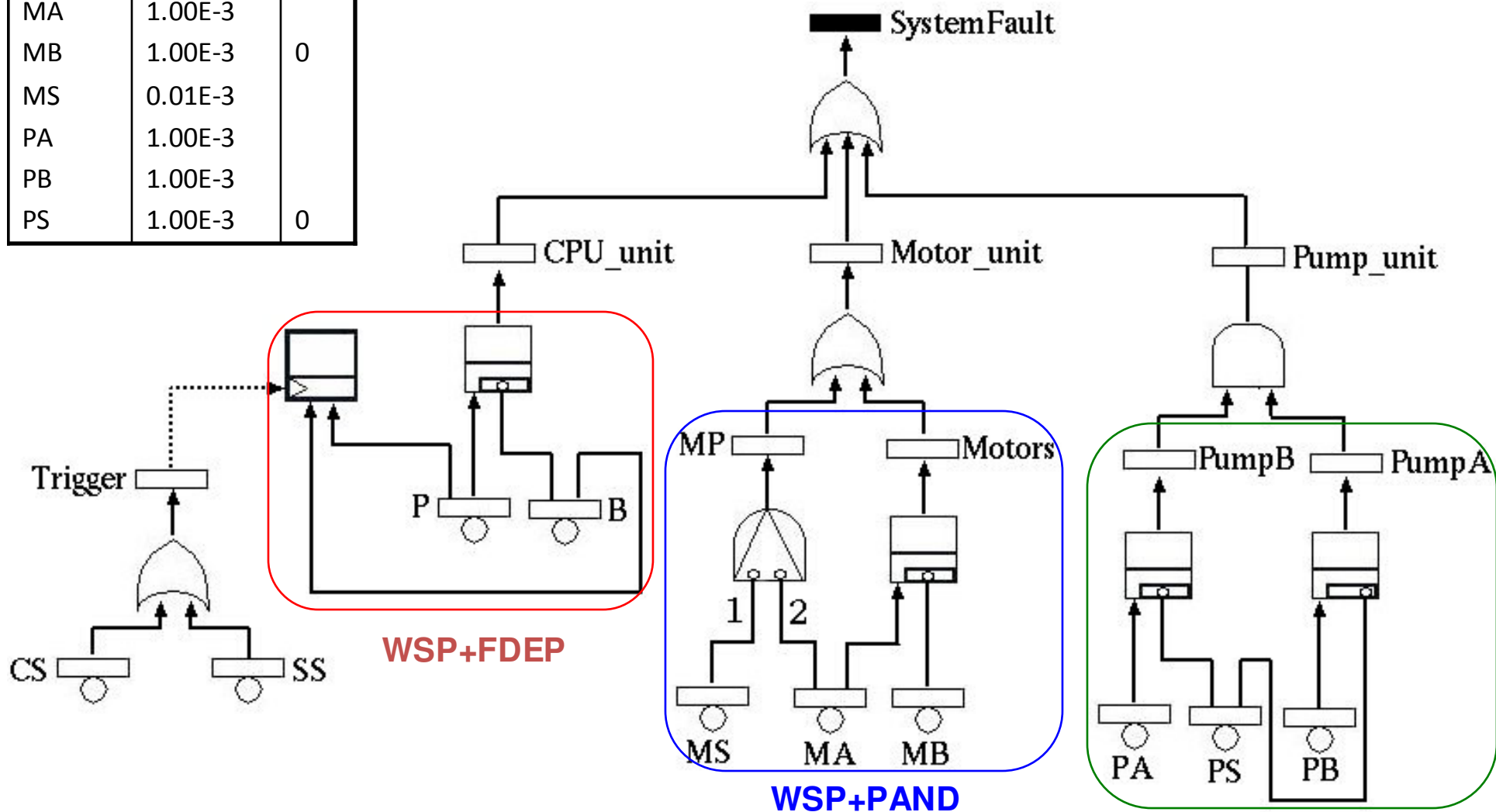

DFT analysis

- DFT relaxes assumptions holding for FT
- DFT analysis must capture the system evolution during the time. Solutions:
 - DFT \rightarrow BDD + CTMC (modular approach)
 - Dynamic module \rightarrow Continuous Time Markov Chains (CTMC)
 - Univ. of Virginia
 - Dynamic module \rightarrow (Colored) Stochastic Petri Nets \rightarrow CTMC
 - Univ. del Piemonte Orientale
 - DFT \rightarrow algebraic formula including \triangleleft operator
 - ENS Cachan
 - DFT \rightarrow I/O Interactive Markov Chains
 - Univ. of Twente
 - **DFT \rightarrow Dynamic Bayesian Networks (DBN)**

DBN for DFT analysis

- DBN remove the assumption on binary events
 - Multistate components
- DBN remove the assumption on statistical independence
 - Event dependency
- DBN remove the assumption on Boolean gates (AND, OR)
 - Noisy OR, noisy AND
 - Dynamic gates
- DBN provide a more flexible forward and backward analysis, possibly based on observations
 - Forward (predictive) analysis: $\Pr(\text{TE})$, $\Pr(\text{Sub})$, $\Pr(\text{TE} | A)$, $\Pr(\text{Sub} | A)$
 - Backward (diagnostic) analysis: $\Pr(A | \text{TE})$, $\Pr(\text{Sub} | \text{TE})$, ...
- DBN avoid the state space generation
 - The model does not enumerate all the system states and transitions

DFT conversion into DBN

- Modular approach:
 - First, every single gate is converted into DBN
 - Then, the resulting DBNs are connected together in correspondance to the nodes they share.
 - Connection of DBN1 with DBN2
 - An adjustment to the CPT of a node is required when new arcs enter the node:
 - add all the parents derived from DBN1 and DBN2 as columns in the new CPT;
 - in every entry of the table, set the probability of failure of the node to the maximum between the corresponding entries of the CPT in DBN1 and in DBN2
- The connection of all the DBNs corresponding to the single gates, provides the DBN expressing the DFT model.

Warm Spare gate

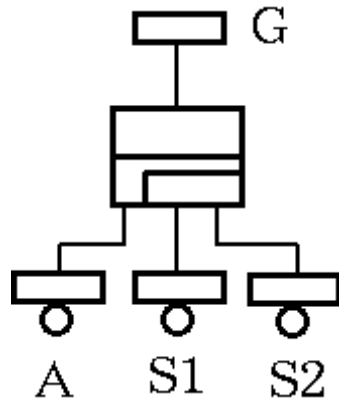

- A is the main component
 - failure rate: λ
- S1, S2 are the warm spare components
 - stand by $\rightarrow \alpha\lambda$ α is the dormancy factor ($0 < \alpha < 1$)
 - working $\rightarrow \lambda$

$$\Pr\{A(t+\Delta)=1|A(t)=1\}=1$$

$$\Pr\{A(t+\Delta)=1|A(t)=0\}=1-e^{-\lambda_A \Delta}$$

$$\Pr\{S1(t+\Delta)=1|S1(t)=1\}=1$$

$$\Pr\{S1(t+\Delta)=1|A(t)=0, S1(t)=0\}=1-e^{-\alpha\lambda_{S1} \Delta}$$

$$\Pr\{S1(t+\Delta)=1|A(t)=1, S1(t)=0\}=1-e^{-\lambda_{S1} \Delta}$$

$$\Pr\{S2(t+\Delta)=1|S2(t)=1\}=1$$

$$\Pr\{S2(t+\Delta)=1|A(t)=0, S1(t)=0, S2(t)=0\}=1-e^{-\alpha\lambda_{S2} \Delta}$$

$$\Pr\{S2(t+\Delta)=1|A(t)=0, S1(t)=1, S2(t)=0\}=1-e^{-\alpha\lambda_{S2} \Delta}$$

$$\Pr\{S2(t+\Delta)=1|A(t)=1, S1(t)=0, S2(t)=0\}=1-e^{-\alpha\lambda_{S2} \Delta}$$

$$\Pr\{S2(t+\Delta)=1|A(t)=1, S1(t)=1, S2(t)=0\}=1-e^{-\lambda_{S2} \Delta}$$

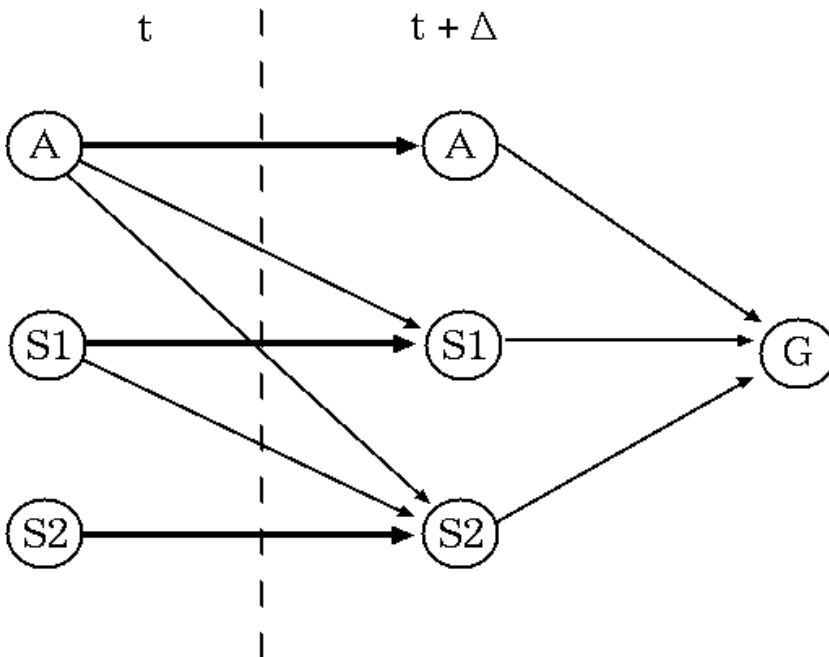

Functional Dependency gate

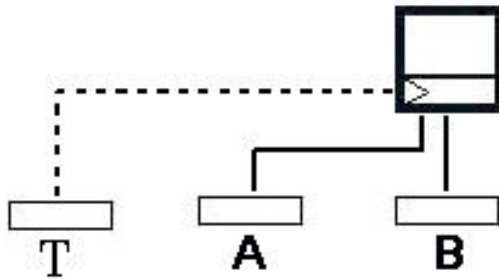

- T is the trigger event
 - failure rate: λ_T
- A, B are the dependent events
 - failure rate: λ_A, λ_B

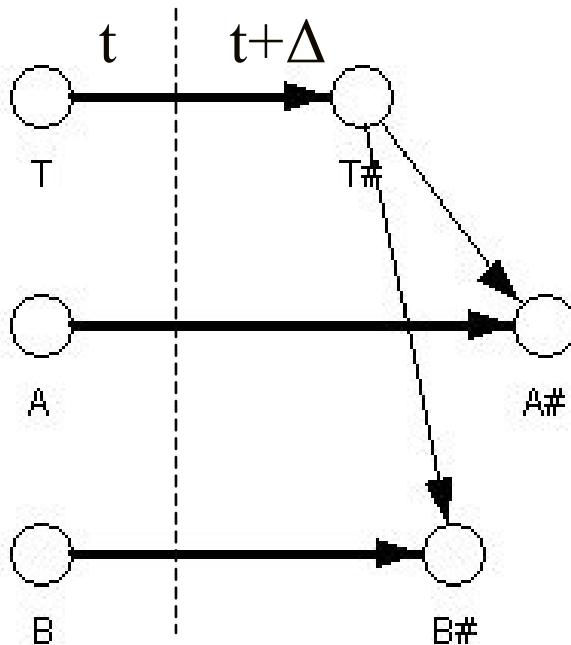

$$\Pr \{T(t+\Delta)=1|T(t)=1\}=1$$

$$\Pr \{T(t+\Delta)=1|T(t)=0\}=1-e^{-\lambda_T \Delta t}$$

$$\Pr \{A(t+\Delta)=1|A(t)=1\}=1$$

$$\Pr \{A(t+\Delta)=1|A(t)=0, T(t+1)=0\}=1-e^{-\lambda_A \Delta t}$$

$$\Pr \{A(t+\Delta)=1|A(t)=0, T(t+1)=1\}=p_{\text{dep}} (=1)$$

Priority AND gate

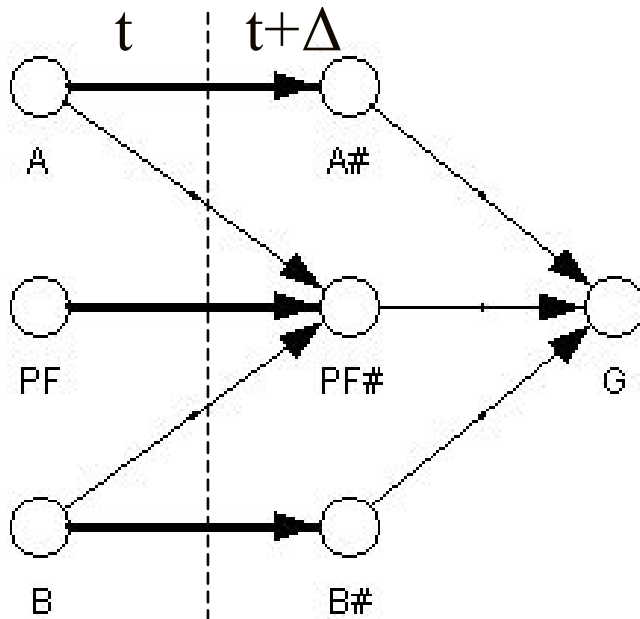
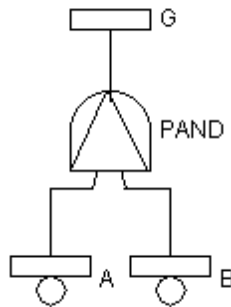

$$\Pr\{A(t+1)=1|A(t)=1\}=1$$

$$\Pr\{A(t+1)=1|A(t)=0\}=1-e^{-\lambda_A \Delta t}$$

$$\Pr\{B(t+1)=1|B(t)=1\}=1$$

$$\Pr\{B(t+1)=1|B(t)=0\}=1-e^{-\lambda_B \Delta t}$$

$$\Pr\{PF(t+1)=1|*,PF(t)=1\}=0$$

$$\Pr\{PF(t+1)=1|A(t)=0, B(t)=0,PF(t)=0\}=0$$

$$\Pr\{PF(t+1)=1|A(t)=1, B(t)=0,PF(t)=0\}=1$$

$$\Pr\{PF(t+1)=1|A(t)=0, B(t)=1,PF(t)=0\}=0$$

$$\Pr\{PF(t+1)=1|A(t)=1, B(t)=1,PF(t)=0\}=1$$

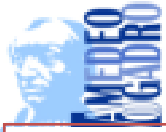

DBN → DFT

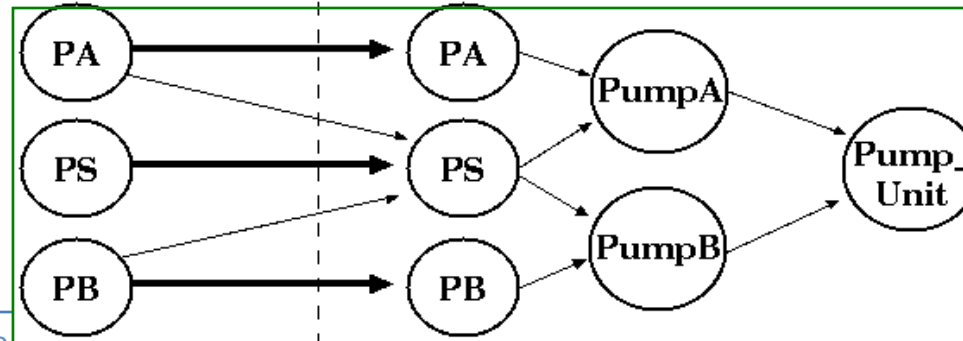
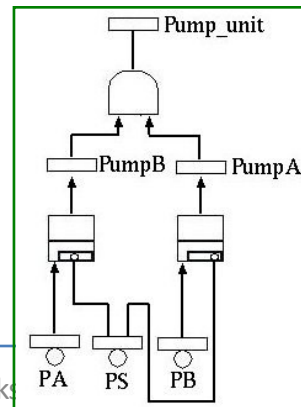
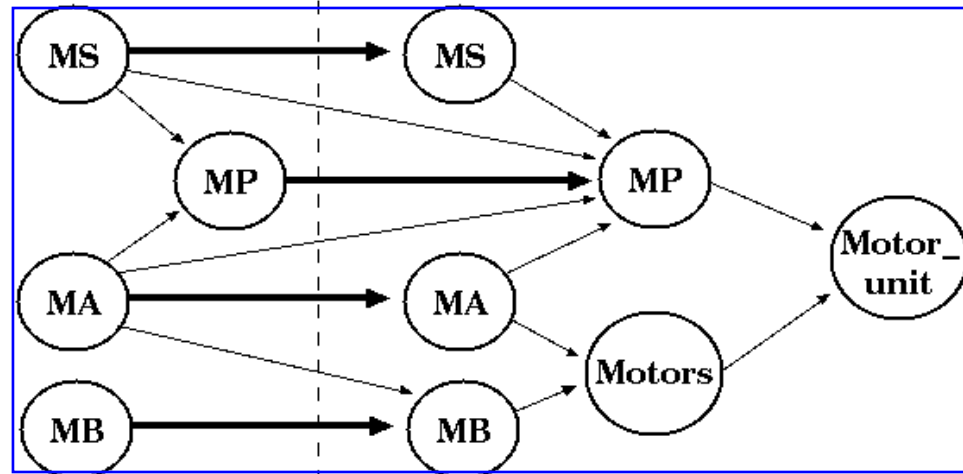
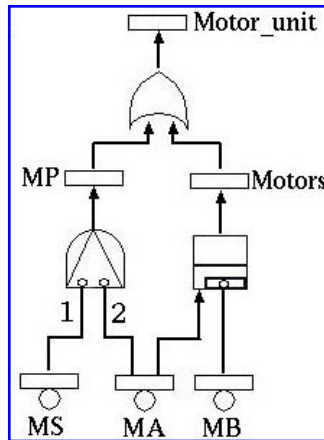
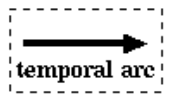
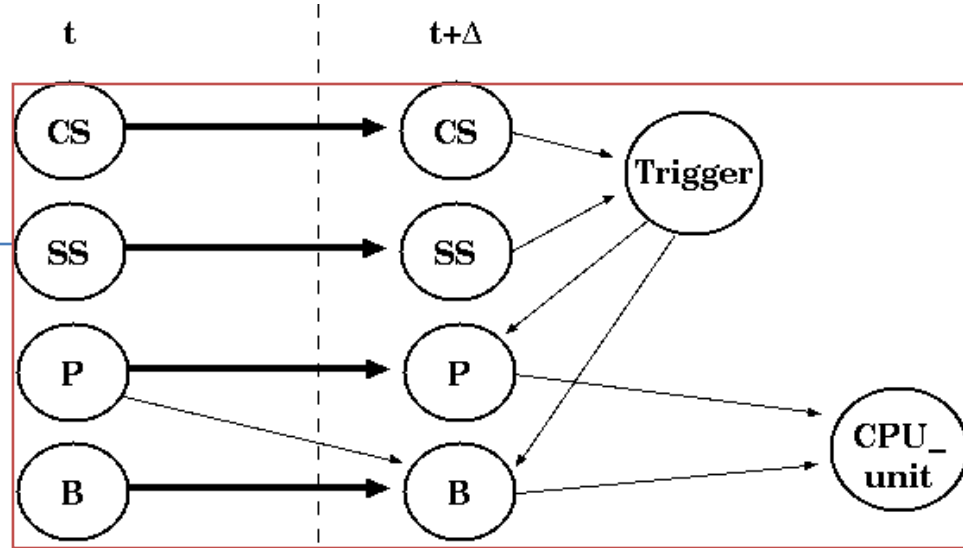
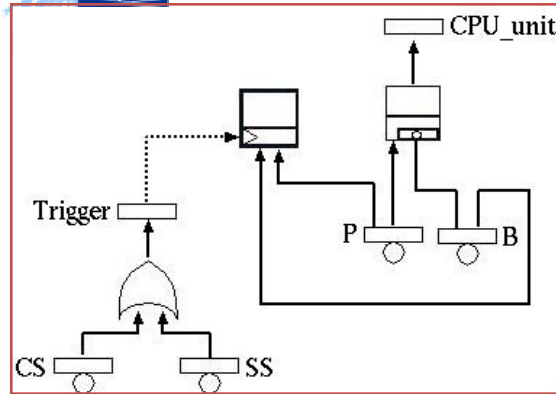

InfQ works

Dipartimento



Inference results

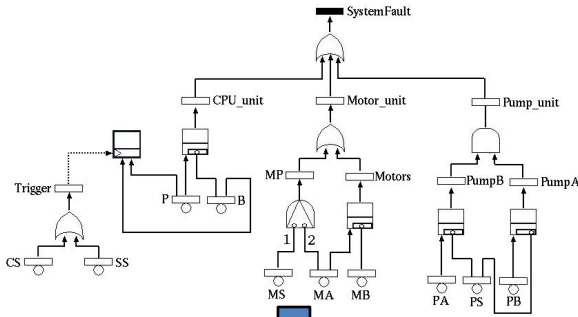

Case of filtering
with no observations

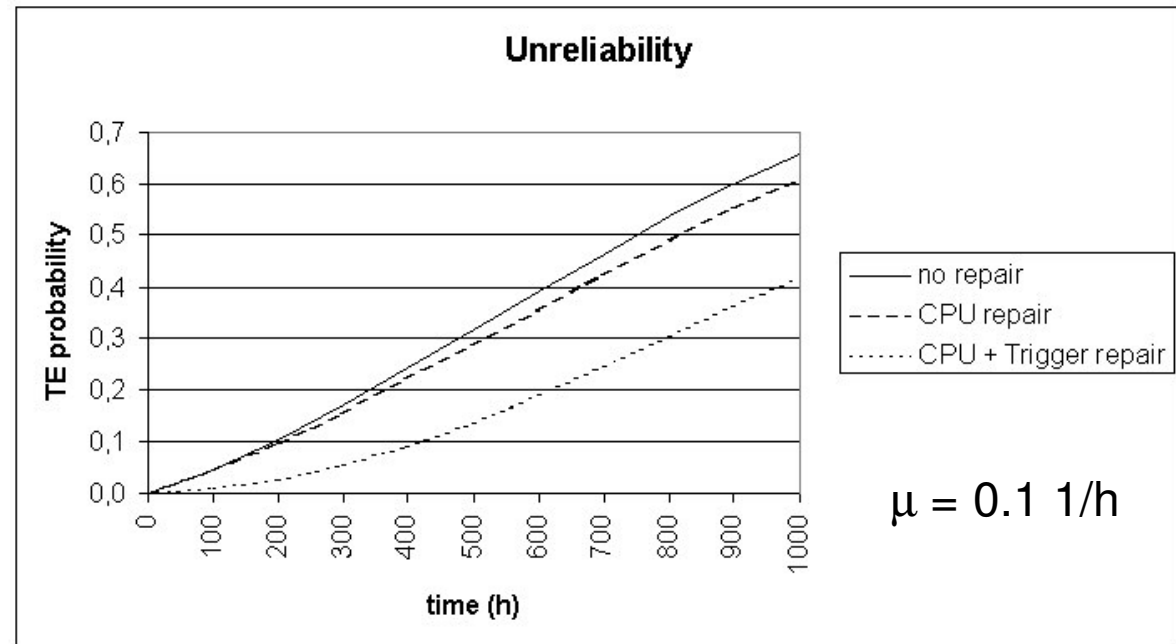
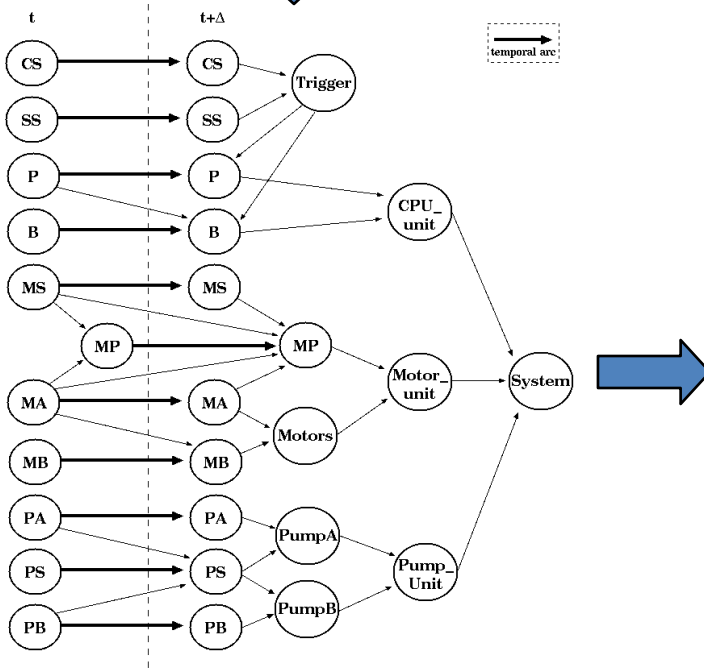

Results comparison

Time (h)	<i>RADYBAN</i> ($k = 1$)	<i>RADYBAN</i> ($k = 0.1$)	<i>Galileo</i>
100	0.045978	0.046026	0.0460314
200	0.103124	0.103214	0.103222
300	0.169204	0.169327	0.169336
400	0.241328	0.241474	0.241483
500	0.316482	0.316645	0.316651
600	0.391893	0.392060	0.392066
700	0.465241	0.465408	0.465411
800	0.534745	0.534908	0.534908
900	0.599169	0.599322	0.59932
1000	0.657763	0.657908	0.6579

Time (h)	<i>RADYBAN</i>		<i>DRPFTproc</i>	
	CPU repair	CPU + Trigger repair	CPU repair	CPU + Trigger repair
100	0.044283796102	0.011243030429	0.0443301588	0.0112820476
200	0.096916869283	0.027566317469	0.0951982881	0.0276517226
300	0.156659856439	0.054836865515	0.155093539	0.0549629270
400	0.221550568938	0.091957211494	0.220137459	0.0921166438
500	0.289382189512	0.137252241373	0.288119742	0.137437204
600	0.358023554087	0.188778832555	0.356905021	0.188981668
700	0.425606846809	0.244557544589	0.424624354	0.244770740
800	0.490624904633	0.302729338408	0.489768367	0.302945892
900	0.551952958107	0.361649900675	0.551211316	0.361864672
1000	0.608829379082	0.419938921928	0.608191065	0.420148205

Inference with observations

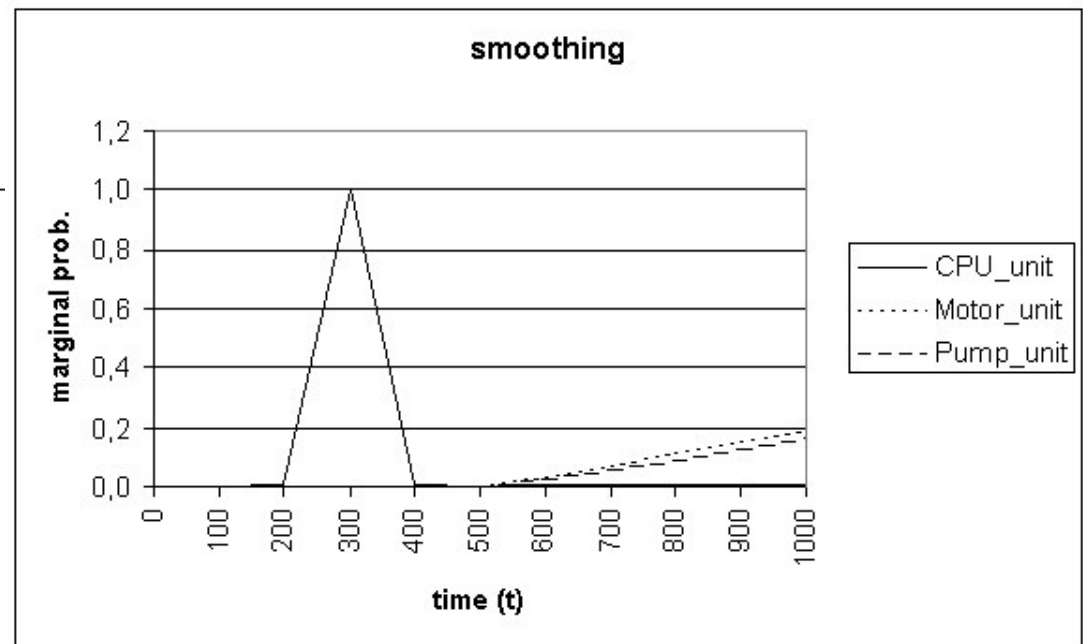
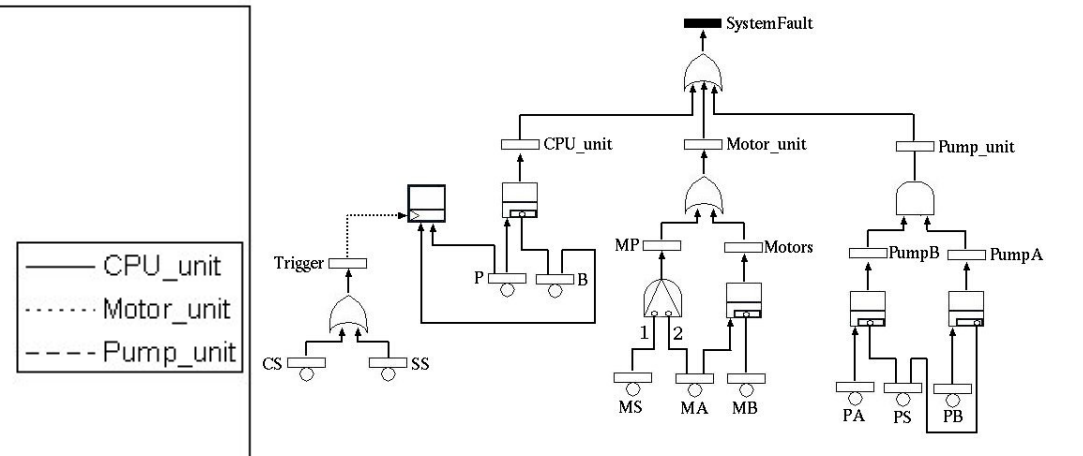
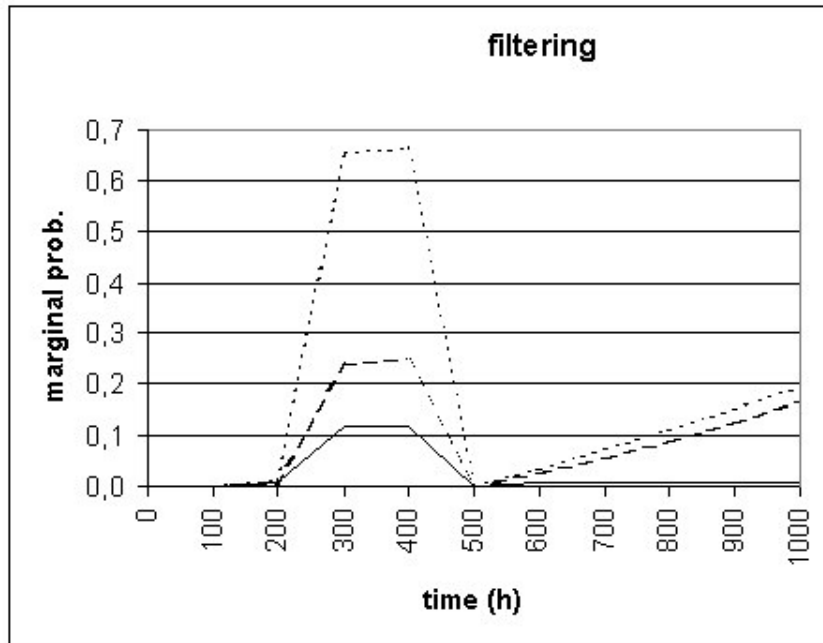

- P, B, CS, SS are repairable
- The system was observed
 - operational at $t_1=100$ h
 - failed at $t_2=300$ h
 - operational $t_3=500$ h

Joint probabilities assuming observations

Time (h)	0,0,0	0,0,1	0,1,0	0,1,1
100	1.000000	0.000000	0.000000	0.000000
200	0.977576	0.003501	0.012862	0.000046
300	0.000000	0.228510	0.643095	0.007708
400	0.110162	0.224175	0.637081	0.022560
500	1.000000	0.000000	0.000000	0.000000
600	0.934621	0.024475	0.033999	0.000890
700	0.870357	0.051434	0.068166	0.004028
800	0.803337	0.079515	0.101124	0.010009
900	0.735453	0.107478	0.131794	0.019260
1000	0.668297	0.134277	0.159387	0.032024
	1,0,0	1,0,1	1,1,0	1,1,1
100	0.000000	0.000000	0.000000	0.000000
200	0.005916	0.000021	0.000078	0.000000
300	0.115366	0.001383	0.003891	0.000047
400	0.000673	0.001357	0.003855	0.000137
500	0.000000	0.000000	0.000000	0.000000
600	0.005655	0.000148	0.000206	0.000006
700	0.005267	0.000311	0.000413	0.000024
800	0.004861	0.000481	0.000612	0.000061
900	0.004450	0.000650	0.000798	0.000117
1000	0.004044	0.000813	0.000964	0.000194

Conclusions

- Several classes of model can be applied in the Dependability/Reliability field
- DBN extend BN introducing a temporal dimension
 - Several kinds of inference: filtering, prediction, smoothing
- RADYBAN allows to
 - Edit and analyze a DBN
 - Edit and analyze a DFT through conversion into DBN
 - Possibility of computing measures conditioned by observations
 - DBN avoid the state space generation
 - DFT can be an high-level formalism to generate DBN

Future work

- Implementing in RADYBAN the possibility of modeling the repair of subsystems in the DFT
 - Several repair policies are already defined, together with the corresponding conversion rules $DFT \rightarrow DBN$
- VeriFIM project: collaboration with Alenia, ESA
 - Development of a DBN analyzer based on Junction Tree (JT) algorithm, to be run on board of a rover
 - Goals: diagnosis, prediction and recovery of the rover according to the observations coming from the rover's sensors
 - The DBN (and the JT) will be derived from the DFT of the rover by means of RADYBAN (off board)

REFERENCES

- DBN P. Weber, L. Jouffe, "Reliability modelling with dynamic Bayesian networks", *Proc. SAFEPROCESS 2003*, Washington D.C., 2003.
- DBN Murphy K. Dynamic Bayesian networks: representation, inference and learning. PhD thesis, UC Berkley; 2002.
- DFT J. B. Dugan, S. J. Bavuso, M. A. Boyd, "Dynamic Fault-Tree Models for Fault-Tolerant Computer Systems", *IEEE Trans. on Reliability*, vol 41, 1992, pp 363-377.
- DFT R. Manian, D. W. Coppit, K. J. Sullivan, J. B. Dugan, "Bridging the Gap Between Systems and Dynamic Fault Tree Models", *Proc. Annual Reliability and Maintainability Symposium*, 1999, pp 105-111.
- ~ ~ ~
- DFT→ DBN S. Montani, L. Portinale, A. Bobbio, D. Codetta Raiteri, "*RADYBAN: a tool for Reliability Analysis of Dynamic Fault Trees through Conversion into Dynamic Bayesian Networks*", *Reliability Engineering and System Safety*, vol. 93(7), pages 922-932, Elsevier, July 2008
- DFT→ DBN L. Portinale, D. Codetta-Raiteri, S. Montani, "*Supporting Reliability Engineers in Exploiting the Power of Dynamic Bayesian Networks*", *International Journal of Approximate Reasoning*, vol. 51(2), pages 179-195, Elsevier, Jan. 2010.
- DBN applications D. Codetta-Raiteri, A. Bobbio, S. Montani, L. Portinale, "*A dynamic Bayesian network based framework to evaluate cascading effects in a power grid*", *Engineering Applications of Artificial Intelligence*, Elsevier (to appear).

REFERENCES (free download)

- DFT → DBN L. Portinale, A. Bobbio, D. Codetta-Raiteri, S. Montani, *"Compiling Dynamic Fault Trees into Dynamic Bayesian Networks: the RADYBAN tool"*, CEUR Workshop Proceedings, vol. 268, August 2007. Proceedings of the Bayesian Modeling Applications Workshop, Vancouver, Canada, July 2007, <http://sunsite.informatik.rwth-aachen.de/Publications/CEUR-WS/Vol-268/>
- DFT → DBN S. Montani, L. Portinale, A. Bobbio, M. Varesio, D. Codetta-Raiteri, *"DBNet, a tool to convert Dynamic Fault Trees into Dynamic Bayesian Networks"*, Dip. di Informatica, Univ. del Piemonte Orientale, TR-INF-2005-08-02-UNIPMN, August 2005, http://www.di.unipmn.it/index.php?page=technical_reports&year=2005
- DFT → DBN S. Montani, L. Portinale, A. Bobbio, *"Dynamic Bayesian Networks for Modeling Advanced Fault Tree Features in Dependability Analysis"*, Dip. di Informatica, Univ. del Piemonte Orientale, TR-INF-2004-03-04-UNIPMN, March 2004, http://www.di.unipmn.it/index.php?page=technical_reports&year=2004
- BN Luigi Portinale Helge Langseth, *"Bayesian Networks in Reliability"*, Dip. di Informatica, Univ. del Piemonte Orientale, TR-INF-2005-04-01-UNIPMN, April 2005, http://www.di.unipmn.it/index.php?page=technical_reports&year=2005